



# Manhole Products

**72" Type 2 Precast Catch Basin  
w/ Baffle Type Flow Restrictor  
WSDOT B-10.40-03**

### Grade Adjustment Rings Available

- 2", 3", 4", 6"

### Hole or Knock Out Dimensions

- Maximum hole size is 60 inches
- 12 inches of minimum distance between holes
- 2 inch diameter lifting holes provided
- Cored, cast-in and custom block-out/knock-outs available

### Conformity Standards

- ASTM C478 manhole
- ASTM C443 rubber gasket joint
- ASTM D4101 polypropylene steps and ladders
- Washington State APWA / WSDOT Standard

### Options Available

- Concrete baffle wall shown at 6 inches thick
- Available with steps
- #4 deformed bar at 12 inch spacing each way
- Specialized coatings available
- Kor-N-Seal boots
- 1' thru 10' Polypropylene ladders
- Center hole flat tops
- Mastic

### Section Specifications

Height	Section	Base
12"	1,731 LBS	4,737 LBS
24"	3,499 LBS	6,505 LBS
36"	5,266 LBS	8,272 LBS
48"	7,034 LBS	10,040 LBS
60"	8,802 LBS	11,808 LBS
72"	10,569 LBS	13,575 LBS

Base Slab	Flat Top
3,757 LBS	3,982 LBS

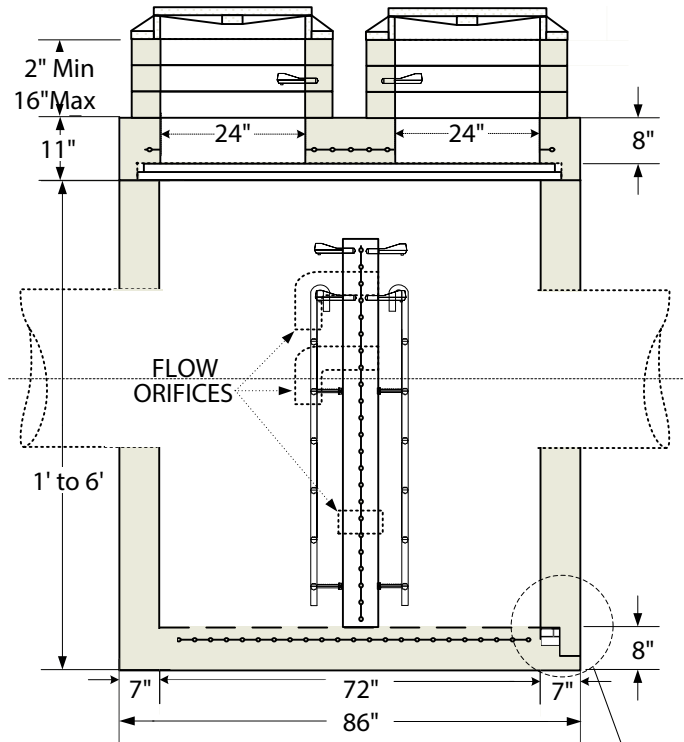

**Top Plan View**

**Gasket Shown Uncompressed**

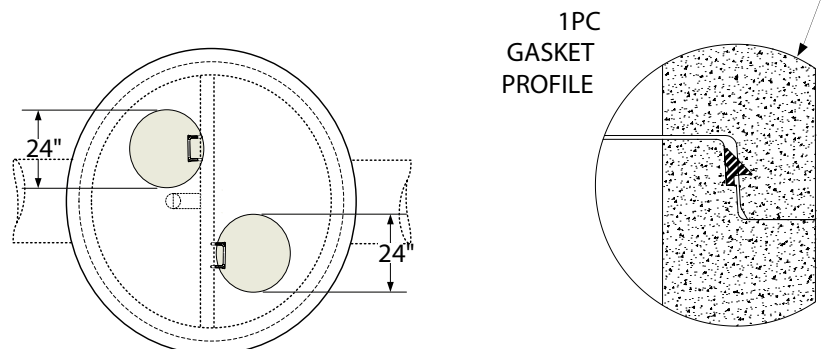

Note: Drawings not to scale

[www.shopeconcrete.com](http://www.shopeconcrete.com)

1-800-422-7560 [TOLL FREE]



Shope Concrete, LLC  
1618 East Main Avenue  
Puyallup, WA 98372-3142

(253) 848-1551  
Fax Line 1 (253) 845-0292  
Fax Line 2 (253) 864-6172

